

The ejector a is provided below with a socket b, and at the top with a tooth c, which pounces in front of the cartridge-rim.

During the backward travel of the frame the ejector is in a vertical position, its socket sliding on the flats of the ejector-block; not until the socket b pushes against the projection d, the ejector turns, expelling the empty cartridge-case

Through this arrangement of the ejection is gained greater strength and stability in the first place, and secondly that the ejector moves 90 degrees, that is to say, it travels from the vertical position to the horizontal one, so that the case, before the ejector releases it, is brought so far out of the chamber as to ensure a faultless ejection even by high degrees of

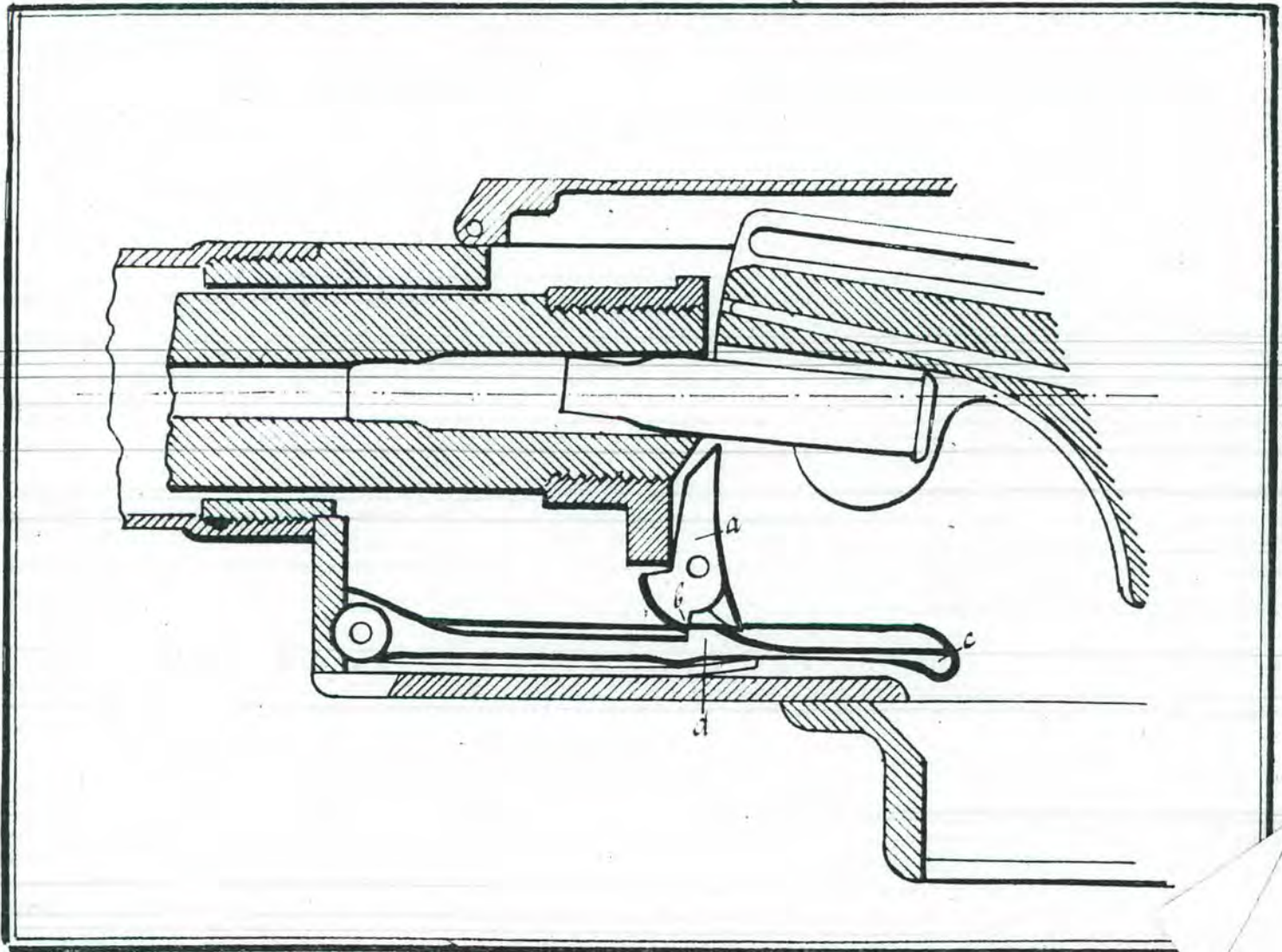

In principle the ejection was effected as follows:-

The ejector a, during its backward travel, slid on the rail c, and when its socket b pushed against the projection d on the rail, the ejector turned 4 m/m away from its vertical position. This motion of the ejector was too short for securing that the case was always thrown entirely out, and more particularly so when the barrel was intensely heated after shooting for a longer time.

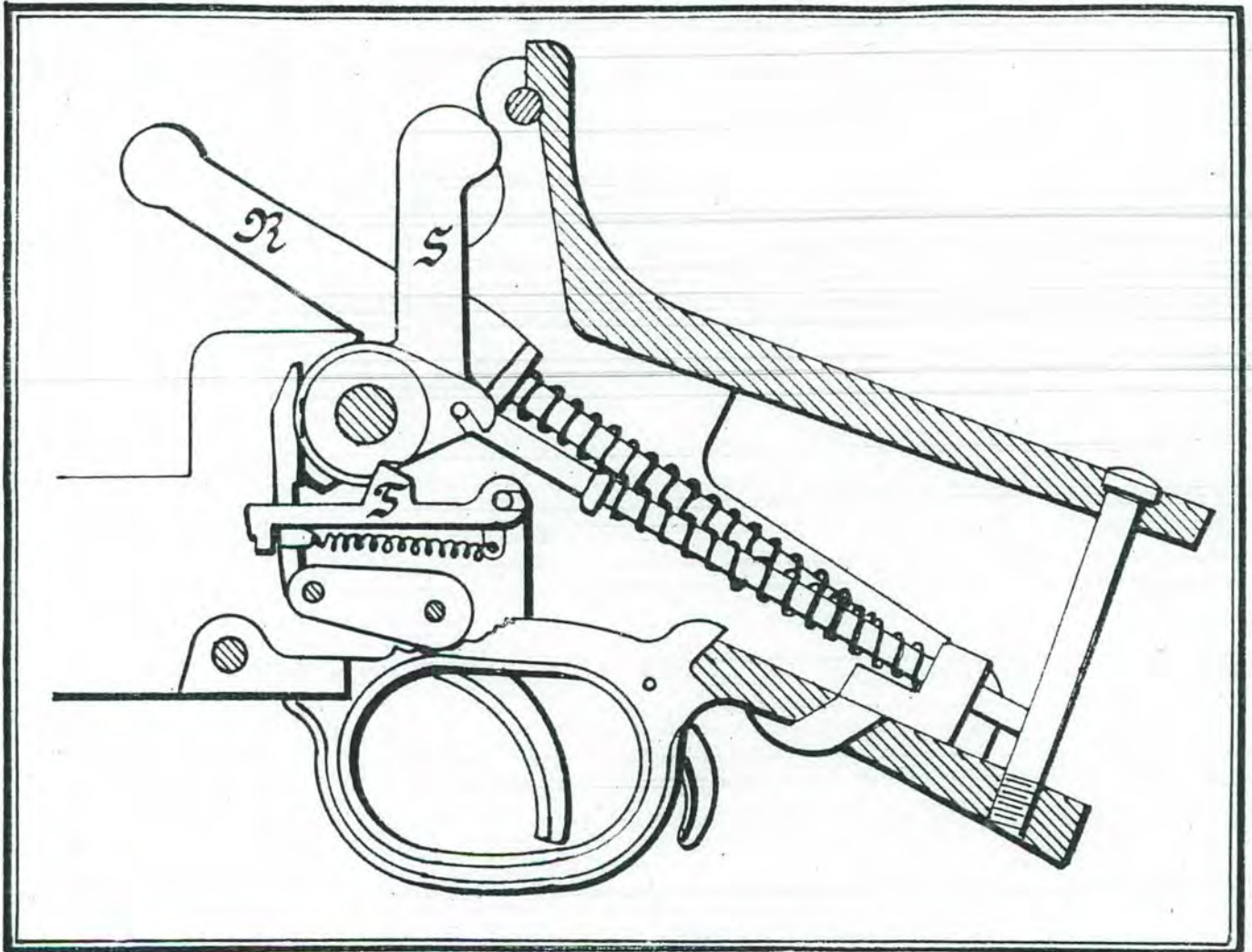

The above drawing shows the component parts of the trigger-mechanism the moment the shooting stops. The percussion-arm S being kept back by the tooth T, the recoil-arm is out in its foremost position, that is to say the mechanism is shut, and there is a cartridge in the chamber. By the alteration of the trigger-mechanism now effected, the recoil-arm, and so the whole of the lock, is kept back in the same way as the percussion-arm.

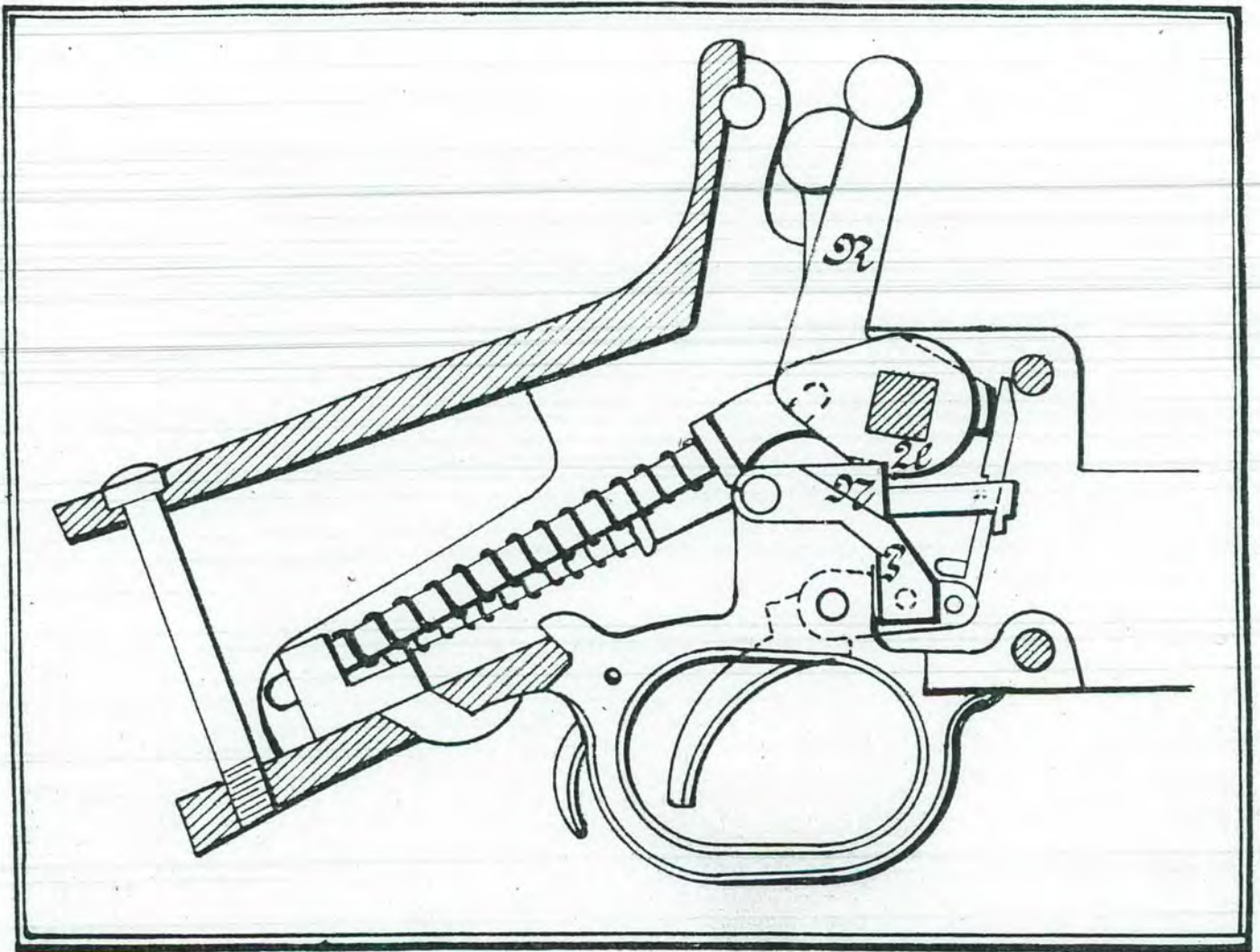

The drawing shows the alteration, the trigger-mechanism being provided with a stop P, the tooth of which N enters a notch U, on the recoil-arm R, this together with the whole of the lock being thus kept back. The spontaneous ignition of the cartridge is thus prevented, as the cartridge, when the lock holds its rearmost position, is not inserted into the chamber and touching only the entirely cold parts of the lock. When the shooting is to be recommenced, the gunner presses the trigger, thereby effecting the insertion of the cartridge into the chamber as well as its ignition.

Model 1904.

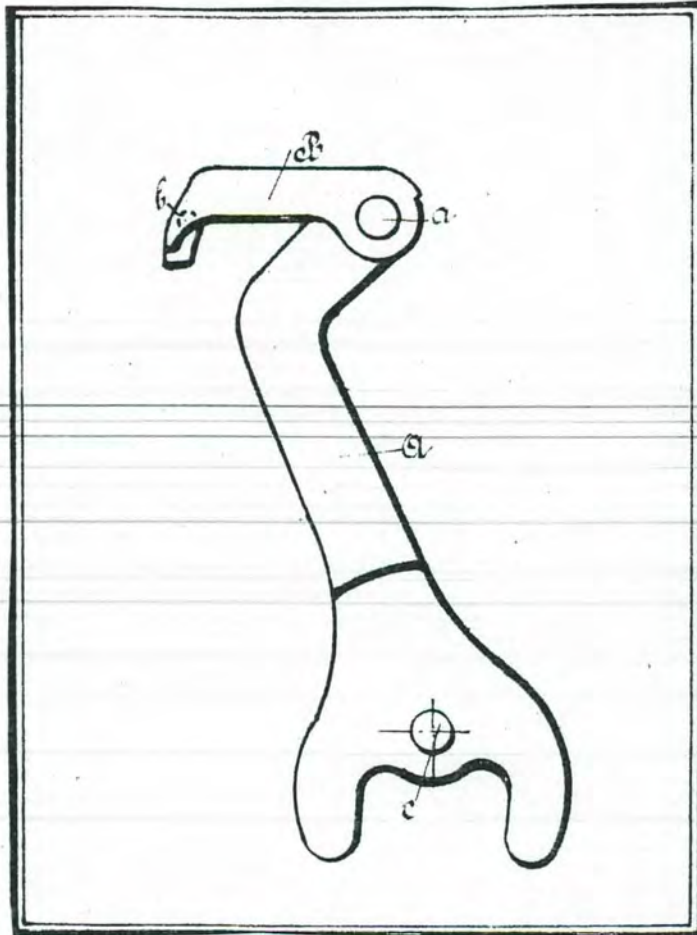

The above drawing represents the cartridge-feeder. It was composed of 2 parts, A and B, connected by the pin a. Moreover the piece B was provided with a pivot b sliding in a groove on the breech-block.

The cartridge-feeder thus consisted of 4 pieces in all, of which B, a, and b have now been dropped.

Model 1912.

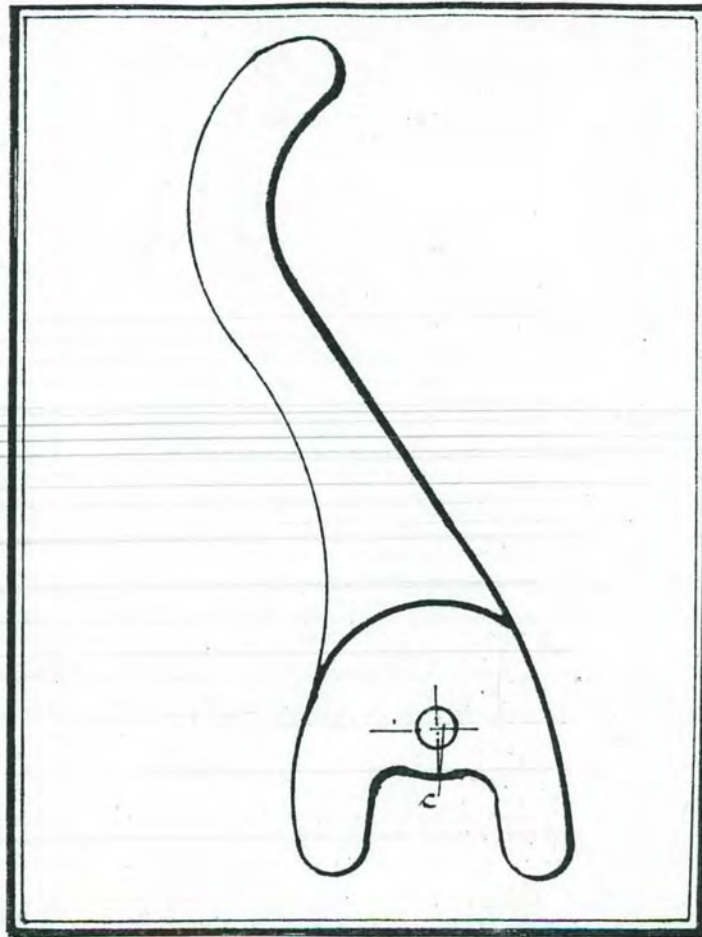

At present the cartridge-feeder consists of only 1 piece, rotating round the pin c.

By this reconstruction is gained a simpler and stronger way of inserting the cartridge into the chamber, and the cartridge-feeder is not exposed to fractures.

Model 1904.

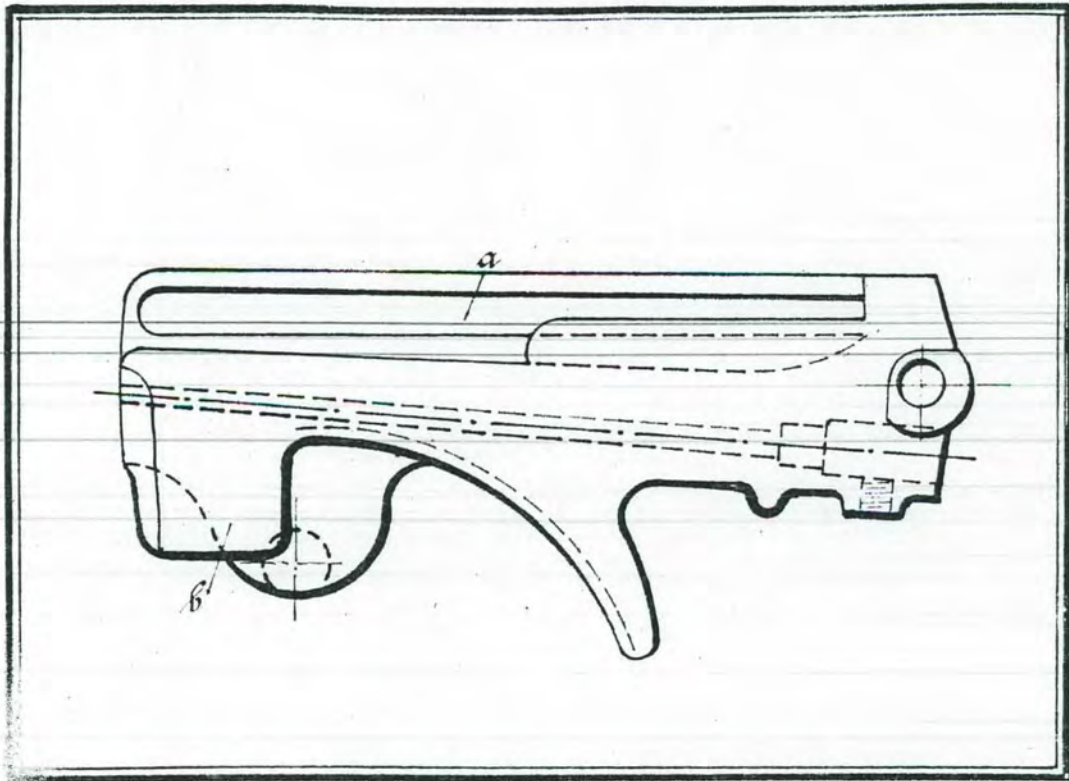

At the top of the breech-block there was a groove a in which slid a pivot on the top of the cartridge-feeder. At the front on the left there was a locking-link b, guiding the motion of the breech-block in the frame. The groove for the pivot of the cartridge-feeder as well as the locking-link b have now been dropped.

Model 1912.

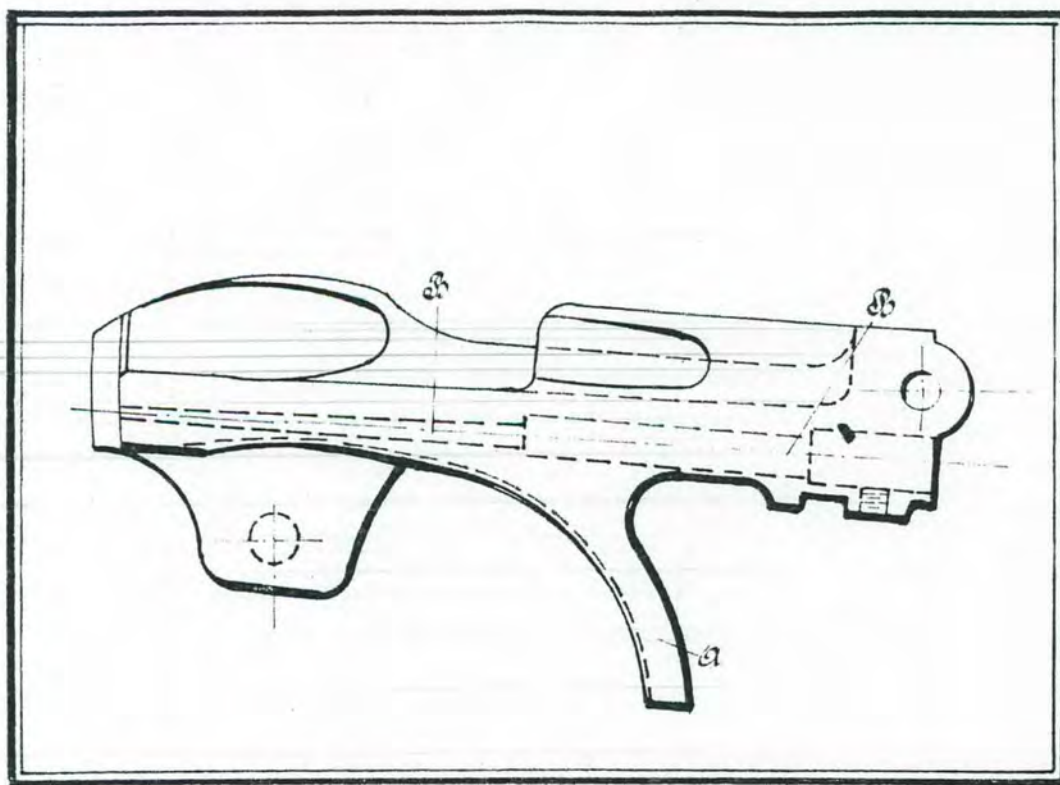

In addition to the alterations indicated on the preceding page, the breech-block has been newmodelled as follows:-

The ejector-plane has been taken more to the rear, so that there is now more room for the cartridge-case when thrown out of the chamber.

The perforation B of the firing-pin has been expanded, and so it has become possible to make the same stronger as well as bigger.

Model 1904.

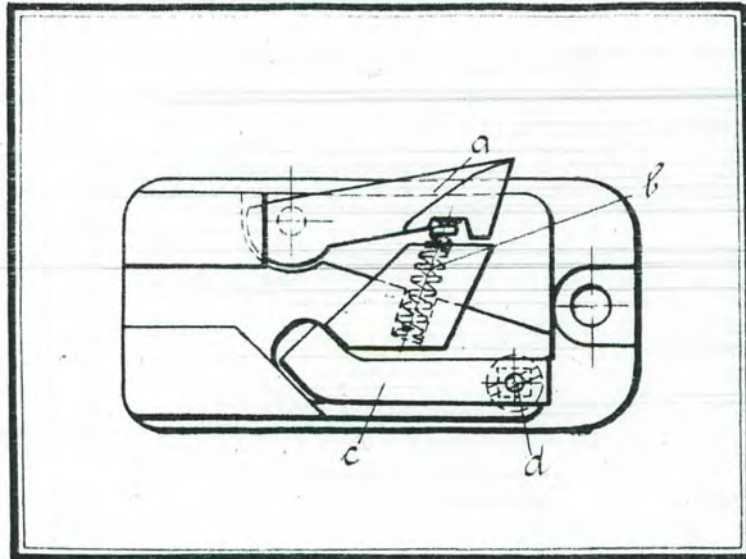

The guiding-plate consists of 1 piece; the import of this arrangement is evident in that the pivot of the breech-block now moves round the prismatic block without being actuated by springs.

Model 1912.

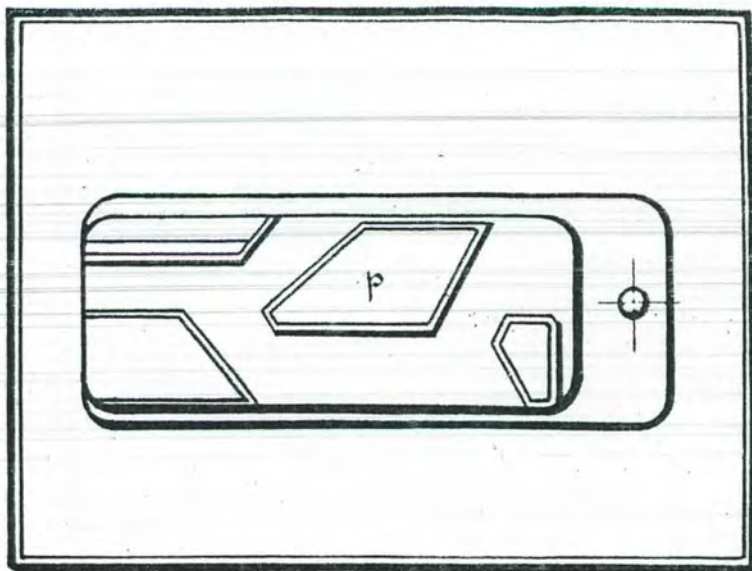

As it appears by the above drawing the undernamed parts belonged to the guiding-plate:-

The lever a

The spring b

The spring c, and

The screw d.

These 4 pieces have been dropped in the new model 1912.



The above photograph shows the duplicate-barrel belonging to each weapon.

It was designed that the duplicate-barrel should not be used until the action was over and the prime barrel worn out. Consequently the duplicate-barrel was not carried in the first line, together with the weapons, but in the second line together with the other reserve-stores.

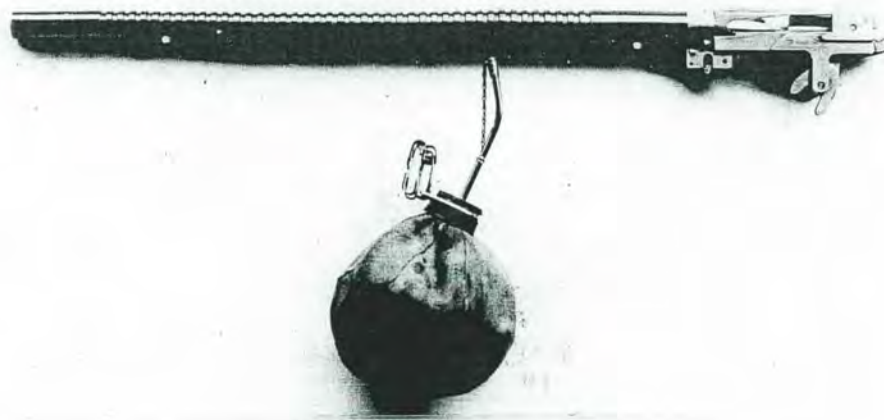

At present belongs to each weapon not only a duplicate-barrel but a duplicate-barrel with mechanism. Hereby the following advantages are gained:-

1) In the course of 30 seconds the duplicate-mechanism can be inserted by the gunner.

2) The change may be performed by the gunner in lying position, which means that it is not necessary to withdraw the weapon from the line of fire, when the change is to be done.

3) The duplicate-mechanism being always carried in the 1st line together with the weapon, its efficiency is more than doubled in that one barrel is cooled while the other is shooting.

If during very forced shooting it should occur that the firing stops in consequence of the defectiveness of either the cartridge or the mechanism, the gunner will now always be able to prevent the ignition of the cartridge due to the heating of the barrel.

For each soldier carries, as shown by the above drawing, a rubber-bag containing 1 liter of water; he being thus always able to cool the barrel, the possibility of spontaneous ignition of the cartridge by the heating of the barrel is entirely precluded.

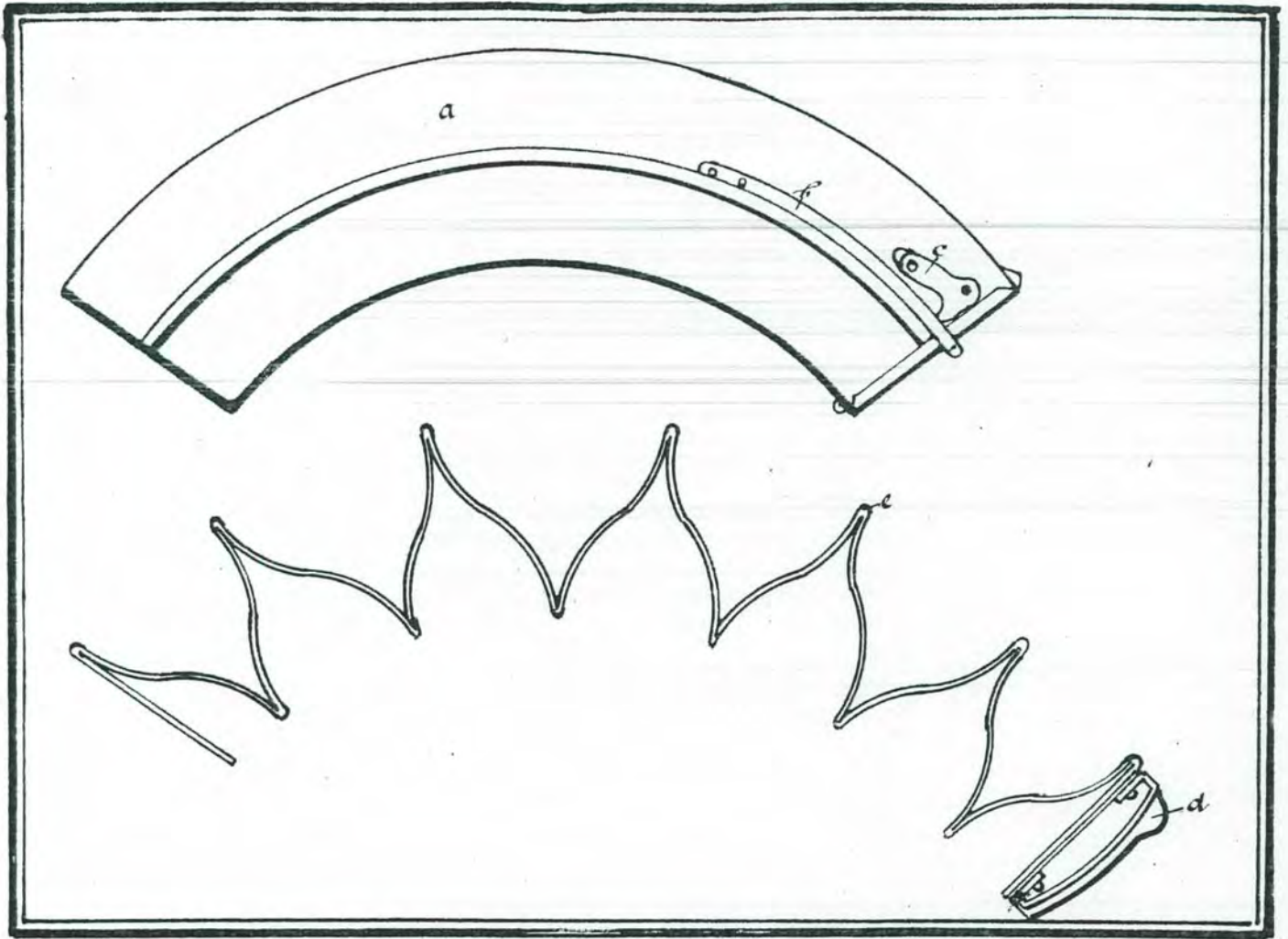

The component parts of the magazine are as follows:-

The magazine a

The cartridge-stop b

The locket of the cartridge-stop c

The cartridge-layer d, and

The magazine-spring e,

5 pieces in all then. At present this number has been reduced to 3,

The locket of the cartridge-stop c, and

The magazine-spring e

having been dropped.

The weight of the magazine was 410 gr.

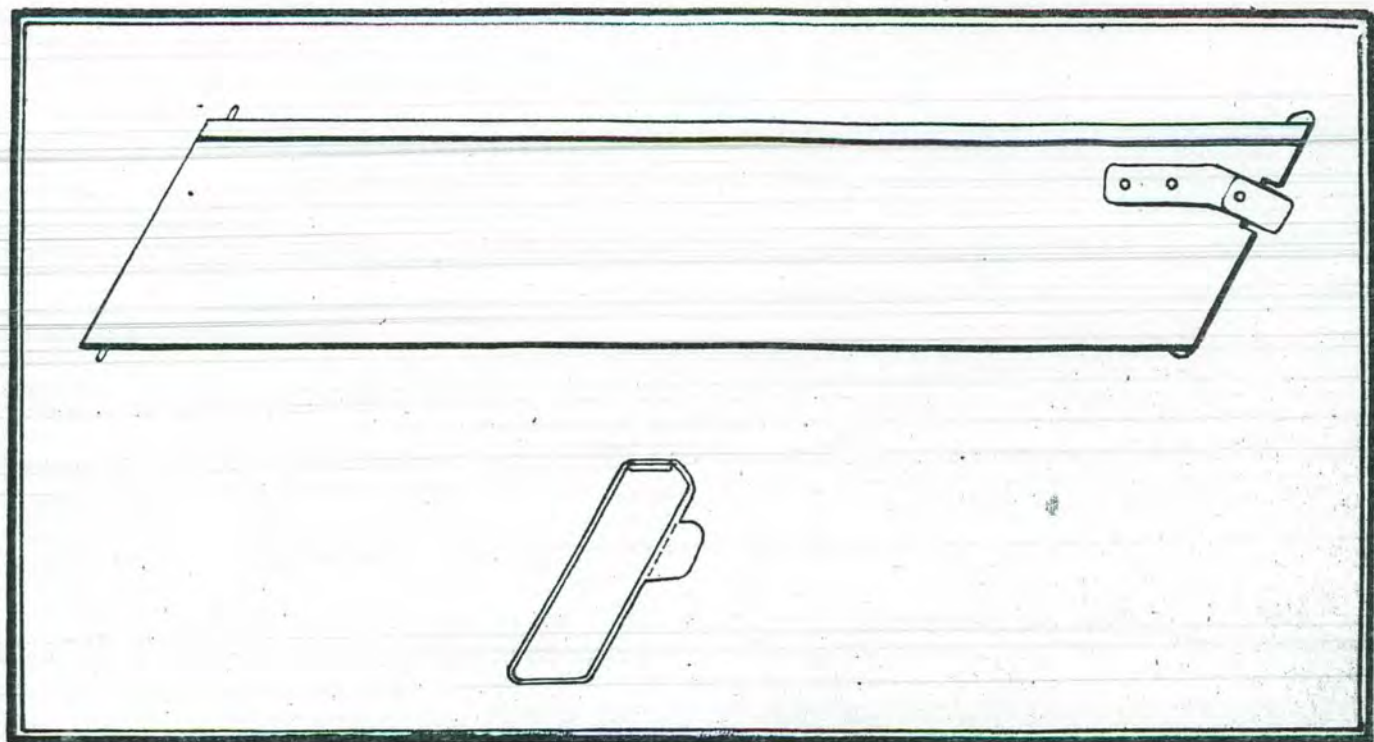

As shown by the drawing the shape of the magazine is now straight, whereas heretofore curved; by this is gained that the magazine can be loaded with greater ease, and the inserting of the cartridge into the rifle-mitrailleuse in an easier and simpler way.

In its present shape the magazine is made of aluminium, and the locket of the cartridge-stop and the magazine-spring having been dropped, the weight of the magazine is 220 gr.

To a packet-horse carrying 2000 cartridges in 80 magazines this means a reduction of weight of 15 kg.

Model 1904.

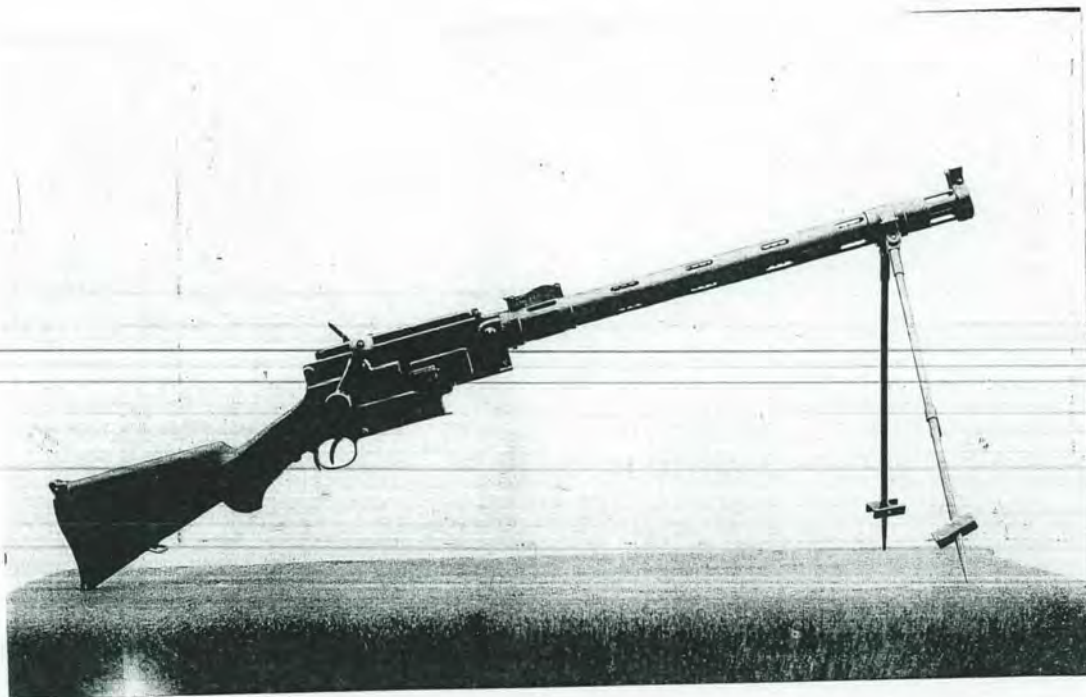

At the front the weapon was provided with 2 support-legs, the maximum elevation of the barrel over the ground being thus about 35 m.

Model 1912.

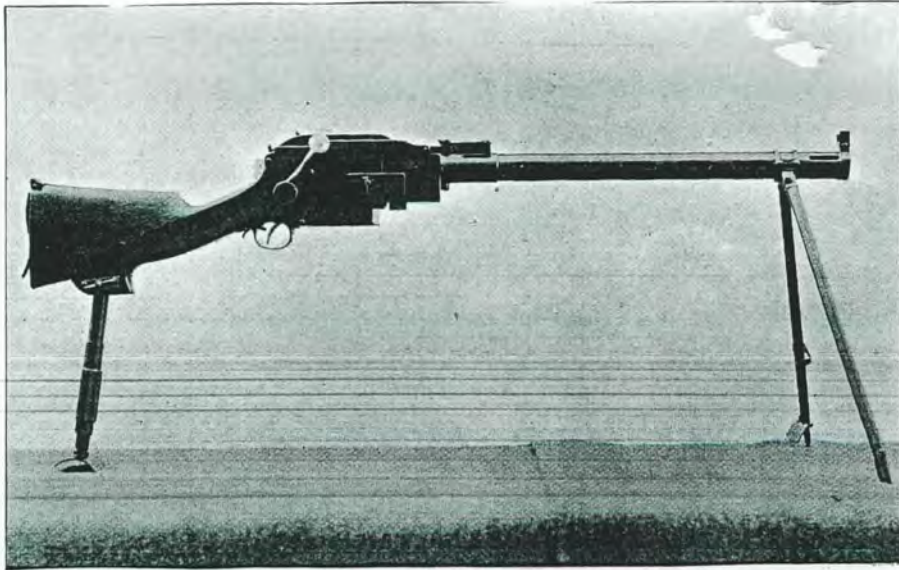

The gunner in lying position.



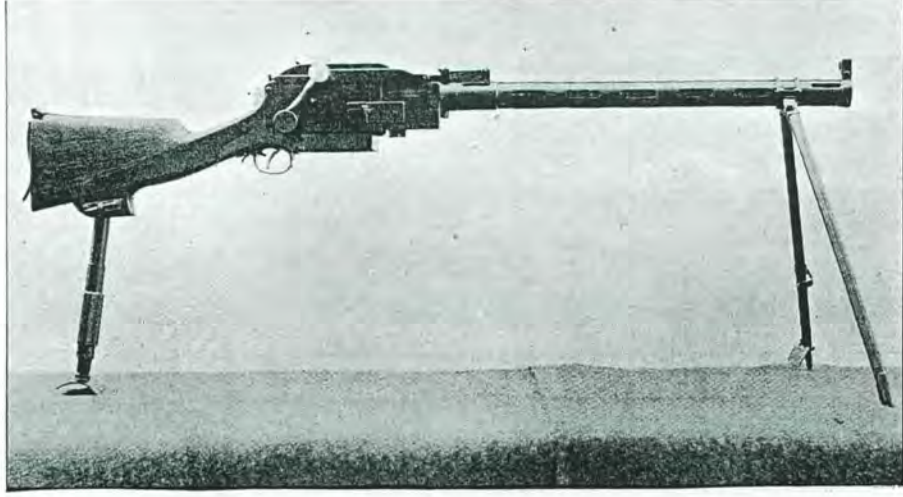

The gunner in lying position.



The means of mounting have been altered as follows:-

- I. The support-legs have been made telescopic, so as to admit shooting in lying as well as in sitting position.
- II. The butt-end is provided with a telescopic support made of indurated aluminium (weight 0,5 kg.), which has considerably increased the accuracy of the weapon.

By way of judging the accuracy of the weapon see appendices 9-10.

The technical corps of the army.
Copenhagen, 10th of December 1912.
2 appendices.

Appendix 9.

Dansk Rekylriffel Syndikat.

Conformably to your wish The technical corps has the honour of forwarding to the Syndikat the annexed result of some shooting experiments made by our corps on the 29th of September last past.

These experiments took place on the shooting-ground of the army, and were performed with the rifle-mitrailleuse system Madsen, model 1912, in order to compare the same with the rifle-mitrailleuse model 1903 which is regulated for the army.

(signed) Nørresø.

Academic rifle-corps.
Copenhagen 12th of December 1912.

Appendix 10.

Dansk Rekylriffel Syndikat.

Conformably to your wish I have the honour of forwarding to the company "Dansk Rekylriffel Syndikat" the annexed result of the shooting experiments performed by our shooting-school with the fifle-mitrailleuse system Madsen, model 1912.

These experiments were performed by the platoon of rifle-mitrailleuse gunners of our corps during the months of May and June, and took place on the shooting-ground of the army.

(signed) E. With,

Captain of the staff,
Commander in chief of the
academic rifle-corps.